



UK & European Registered Design: 686282-001. Patent Pending

FITTING INSTRUCTIONS

Component Parts:



Please read these instructions carefully to familiarise yourself with procedures and component parts before adjusting and fitting your new LaddaLimpet. Please ensure that you have studied the Safety Guidelines before using your LaddaLimpet.

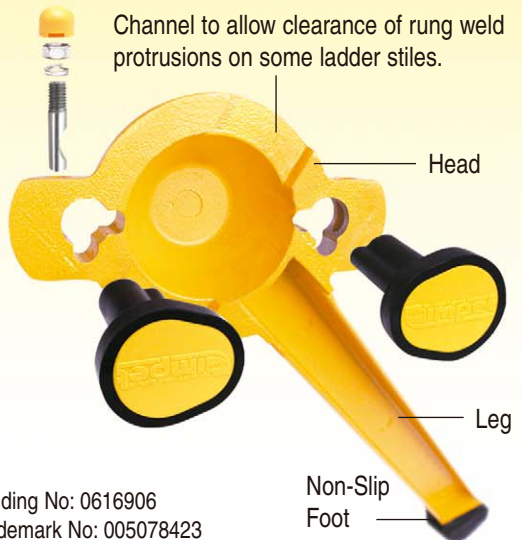
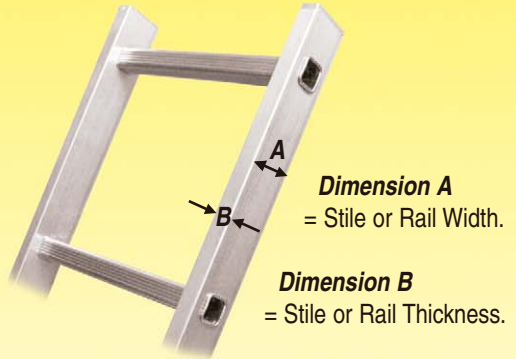

Figure 1. Settings for Ladders 65mm - 78mm.



Standard Ladder Stiles

Ladders with Stile Widths between 65mm - 78mm

1. Leave the support pins in position (see figure 1). Using the M8 Spanner provided, loosen the M8 Nuts just enough to allow the Support Pins to move. Never use excessive force to move the Support Pins. eg. Striking with a hammer.

Figure 2. Setting for Ladders Under 65mm.



Narrow Ladder Stiles

Ladders with Stile Widths under 65mm

2. For ladders with stile widths under 65mm, loosen the M8 Nuts and remove both Support Pins and rotate 90 degrees as shown (see figure 2). Then follow the same procedure as above. Please note that some ladders may only require one pin to be rotated to achieve the correct adjustments.

Figure 3.

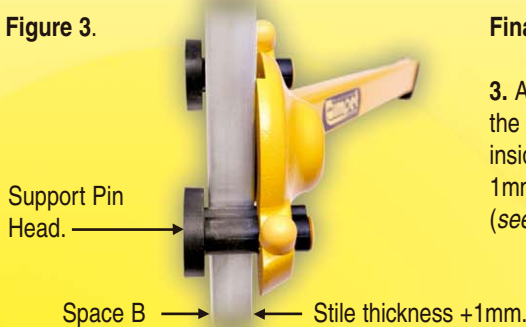

Final Adjustments

3. Adjust the Support Pins until 'Space B' between the inside surface of the 'Support Pin head' and the inside face of the "LaddaLimpet" head is approx 1mm more than the thickness of your ladder stile (see figure 3).

4. Maintaining that space and using the M8 Spanner provided, tighten the M8 Nuts until the Cotter Pin securely locks the Support Pin in place. Repeat this process for the other Support Pins. Check the Support Pins periodically to ensure they remain securely fixed (Do Not Overtighten). Push on the Yellow M8 Nut Covers to protect the Nuts from the elements. Should you need to adjust the Support Pins to suit a different size ladder, gently prize off the Nut Covers with a flat bladed screw driver or by using the tip of the M8 Spanner, and repeat the procedure as before.

YOUR "LADDALIMPET" IS NOW READY TO USE!

HOW TO ATTACH YOUR LADDALIMPET...

1. Holding the LaddaLimpet firmly, clip the front pin over the ladder stile.



2. Push flat, face on, the LaddaLimpet head against the ladder stile.



3. Rotate the head in an anti-clockwise direction until the back pin locates over the back edge of the ladder stile.



4. Slide the LaddaLimpet down the ladder stile until the foot securely locates on a solid surface, eg: ground, wall, step, etc.



HOW TO REMOVE YOUR LADDALIMPET...

5. To remove, lift front pin on Laddalimpet head, slide up ladder stile and reverse attachment procedure.



UK & European Registered Design: 686282-001. Patent Pending

LADDATEC LIMITED - Made in Britain

Laddatec Limited cannot accept responsibility if this product is used, fitted or adjusted outside our recommendations.

This product should not be used with the feet of the ladder off the ground or with the ladder unsupported at the top.

Phoenix House, 6 Bro Stinian, Fishguard, Pembrokeshire, SA65 9RF Tel: 01348 875161 E-mail: info@laddatec.com

Laddatec is a Trade Mark of Laddatec Limited - Registered in England No 5733506

WWW.LADDATEC.COM

'Helping Ladders Stand On Their Own Two Feet !!'